



PROTECTIVE HEIM-JOINT BOOTS - PART # NM.328870

PARTS LIST:
4 - PROTECTIVE HEIM-JOINT BOOTS

TOOLS REQUIRED:
1 - ALL PURPOSE GREASE

1 - WD-40

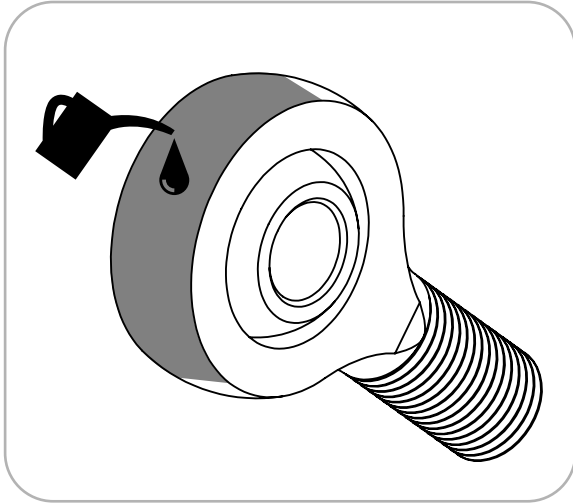

1. Lubricate outside of heim-joint with all purpose grease as shown.

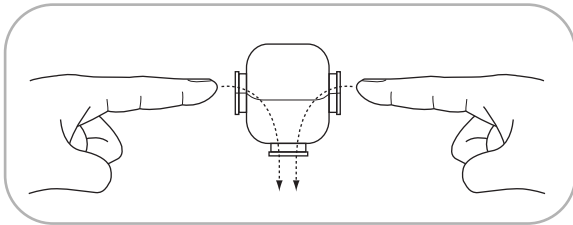

2. Insert fingers into boot as shown above.

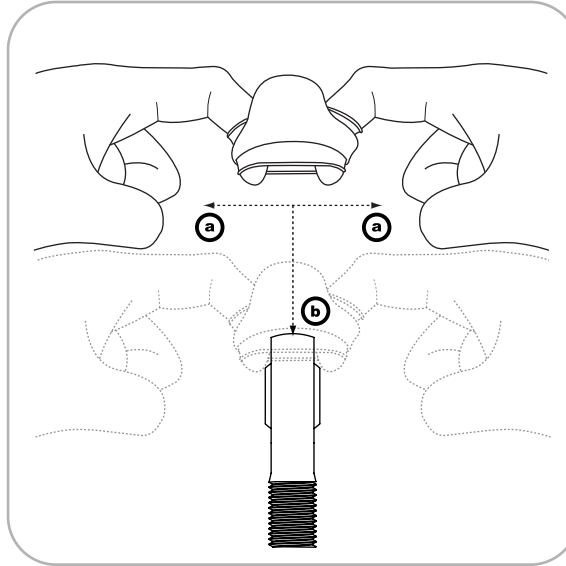

3. Stretch open neck of boot and pull down over lubricated heim-joint.

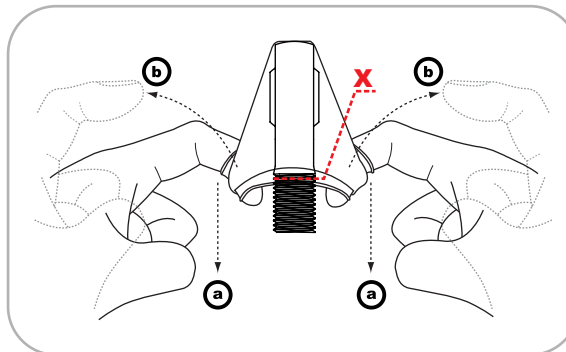

4. The neck of the boot must be pulled down past [x] in figure above. Remove fingers carefully.

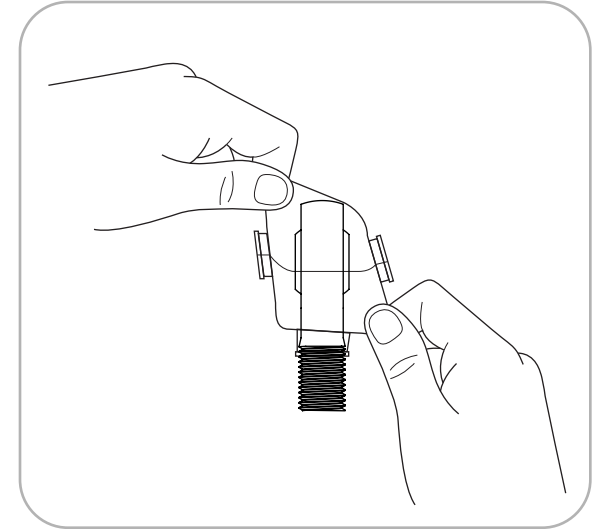

5. Center heim-joint inside of boot for proper fit and hole alignment.

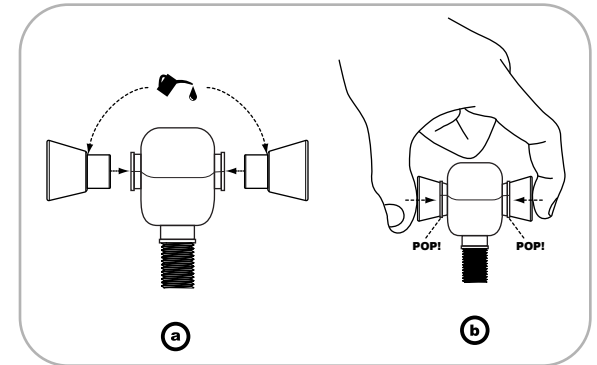

6. Use a small squirt of WD-40 on spacers and insert into boot and heim-joint end. Spacers will subtly pop into place.